

# User Manual

## Display and Data Logger

Model: DIS1



# Notices and Warnings

## Notices

Please **read all of this manual** before you install, operate or maintain this product. Pay attention to notes, warnings and instructions. The manufacturer cannot be held liable for any damage which occurs as a result of noncompliance with this manual.

**Do not tamper with device.** Should the device be tampered with in any manner other than a procedure which is described and specified in this manual, the warranty is cancelled and the manufacturer is exempt from liability.

**The product is designed exclusively for the described application.** Use of this product in conditions not specified in this manual or, contrary to the instructions provided by the manufacturer, is considered improper handling or improper use of the product. Improper handling will void your warranty. The manufacturer will not be held liable for any damages resulting from improper use of the product.

This manual should be read carefully by relevant personnel and the end user. This manual should be kept with the product and be made available as needed. **Once you install or use the product, you accept that you have read, understood and complied with this manual.**

CAA Sensors endeavours to make the content of this manual correct but is not responsible for omissions or errors and the consequences caused. In case of any doubts or questions regarding this manual or the product, please contact CAA Sensors.



## Warnings

**Ignoring the warnings can lead to serious injury and/or cause damage!**

When handling, operating or carrying out maintenance on this product, personnel must employ safe working practices and observe all local health & safety requirements and regulations.

Improper operation or maintenance of this product could be dangerous and result in an accident causing damage to machinery or injury or death.

The manufacturer cannot anticipate every possible circumstance which may represent a potential hazard. The warnings in this manual cover the most common potential hazards and are therefore not all-inclusive. If the user employs an operating procedure, an item of equipment or a method of working which is not specifically recommended by the manufacturer they must ensure that the product will not be damaged or made unsafe and that there is no risk to persons or property.

**NEVER CHANGE ORIGINAL COMPONENTS WITH ALTERNATIVES.**



## Electrical Safety

Contact with energised parts of the product, may lead to an electrical shock which can lead to serious injuries or even death. The user shall take all measures necessary to protect against electrical shock.

### **Follow regulations for electrical installations.**

Do not use this product in explosive environments.

The system must be disconnected from any power supply during maintenance work.

Any electrical work on the system is only allowed by authorised qualified personal.



## Battery Safety

Only use accessories or chargers recommended by the manufacturer.

The built-in battery is not removable. Please contact the manufacturer for repair if needed.

## Storage and transportation

The product should be transported and stored in its original packaging.

Make sure the product is stored at a temperature between -20 to +70°C (-4 to 158°F) and the humidity is <95%, no condensation.

Avoid direct UV and solar radiation during storage.

The manufacturer is not responsible for incidental damage caused by transportation or storage.

## Cleaning

If you need to clean the product it is recommended to use a clean, dry cloth. For stubborn marks, use distilled water or isopropyl alcohol only.



## Disposal

Electronic devices are recyclable material and do not belong in the household waste. The product, accessories and its packing material must be disposed according to local statutory requirements.

# Introduction



# Display & Data Logger

## Intended Use

CAA Sensors' Displays (HMIs) are suitable for use in manufacturing, industrial, pharmaceutical and base building environments providing the product's specifications are met. This includes:

- The HMI is **not** used in pressurised areas.
- Ambient temperature is between: 0 to +50°C (+32 to +122 °F)
- Relative humidity is between 0 to 95% RH
- Power supply is between: 24 to 30 VDC
- The HMI is **not** used in explosive areas.

Refer to the *Specifications* section (next page) for full requirements.

## About the Display (HMI)

The HMI / display is a centralised data acquisition from on-site sensors (both CAA Sensors and third-party sensors). It integrates multi-sensor data collection, logging, and graphical functions.

View data on one display. Export data to USB or output to your SCADA system via Modbus RTU (RS485) or Modbus TCP. The HMI is a fully isolated electrical structure, completely filtering out interference.

## Data Logging

The HMI / Display will record a maximum of 2,000,000,000 (2 billion) values. How long you can record for will depend on how many values you record the frequency of recording data.

**Example 1:** Recording flow, dew point, temperature, relative humidity, wet pressure, dry pressure, kilowatt hours (kWh) for 3 compressors (ie 3 x kWh) and total power at 1 second increments will record 10 values every second.

Therefore:

- 10 values x 60 seconds per minute x 60 minutes per hour x 24 hours per day x 365 days per year = 315,360,000 values per year.
- So 2,000,000,000 / 315,360,000 values per year = 6 years of data recording.

**Example 2:** If you record 30 values every 1 second, you will be able to record data for 2 years.

- 30 values x 60 seconds per minute x 60 minutes per hour x 24 hours per day x 365 days per year = 946,080,000 values per year
- So 2,000,000,000 / 946,080,000 values per year = 2 years of data recording.

# Specifications

Display	7" IPS touch LCD	
Resolution	1280 × 800	
Storage	Data Logging	
	25 G, 2,000,000,000 values	
Data Export	USB Type-C	
	Modbus RTU (RS485) Modbus TCP (Ethernet)	
Digital	Input Signals	
	2 isolated RS485 inputs supports up to 255 Modbus RTU register inputs (data points)	
Analog	4 x channels (Optional)	
	[0...20 mA / 4...20 mA / 0...1 VDC / 0...10 VDC]	
Digital Signal	Outputs	
	Modbus RTU (RS485) Modbus TCP (Ethernet) USB Type-C	
Alarm Signal	2 x relay alarm channel, rated to 24 VDC, 3A	
Power	Power	
	24 to 30 VDC	
Operating Temperature	Working Environment	
	0 to +50°C	+32 to +122 °F
Storage Temperature	-20 to +70°C	-4 to 158°F
Relative Humidity	0 to 95% RH	
Installation	Pipeline / Wall-mounted / DIN-rail	
Connection	Other	
	Wiring Terminal	

Cable Diameter	4 to 8mm	
Protection	IP65	
Housing Material	PC + ABS	
Installation	Wall Mount or Panel Mount or Din Rail	
Dimensions (L×W×H)		
Wall Mount / Din Rail	250.37 x 160.02 x 297.99 mm	9.86" x 6.3" x 3.44"
Panel Mount	200.02 x 160.02 x 118.97 mm	7.87" x 6.3" x 2.36"
Warranty	12 months	

## Dimensions (mm)

### Wall Mount

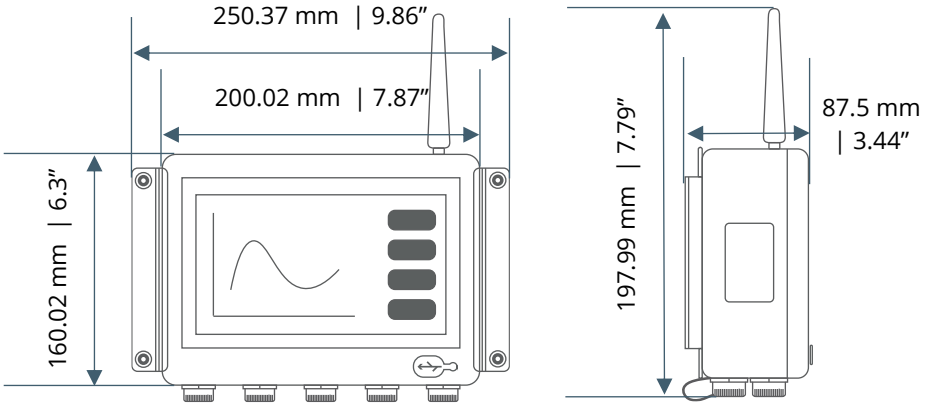

### Panel Mount

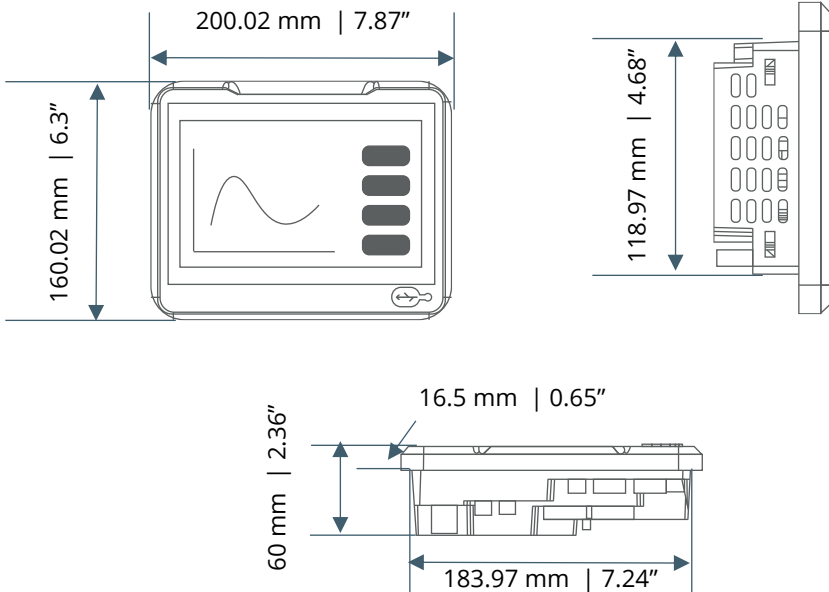

# Display & Data Logger Kit

Each pack comes with:

- HMI – either Panel Mount, Wall Mount or Din rail style



Panel Mount



Wall Mount or  
Din Rail Mount

# Installation



# Installation Overview

**Step 1** – Find a suitable location to install the HMI

**Step 2** – Wire the HMI

**Step 3** – Configure Devices

**Step 4** – Configure Layout

**Step 5** – Configure Alarms

## Notes and Warnings



**WARNING!** Incorrect installation can damage the sensor or cause it to work incorrectly.



### Notes

- Before installing the product, make sure it is rated for your system (refer to the “Specifications” section).
  - Use of the product outside specified ranges or operating parameters can lead to malfunctions and may damage the product or system.
- Do not use this product in explosive areas.
- Do not disassemble the product.
- Always check devices are wired correctly.
- Please follow local and national regulations before/during installation and operation.
- The system must be disconnected from any power supply during installation and maintenance work.
- Only authorised and qualified personnel can conduct electrical work.

# Installation - Mechanical

Find a suitable location to install the HMI. Use one of the mounting methods below – wall mount, din rail mounting or panel mount.

## Wall Mount

Place the HMI at the designated mounting position on the wall. Use four M3 self tapping screws, insert them through the screw holes on the bracket (shown by the green circles in the picture below), and tighten them with a screwdriver.



## Din Rail Mounting

Slide the HMI into the pre installed rail slot on the wall. Adjust its position as needed.



### Panel Mount

The HMI fits into a panel opening with dimensions: Length  $\times$  Height = 220.5  $\times$  120.5 mm, R= 10.5.



Take out the four buckles from the accessories and insert them into the mounting holes on the back of the panel. Fasten them using a screwdriver.

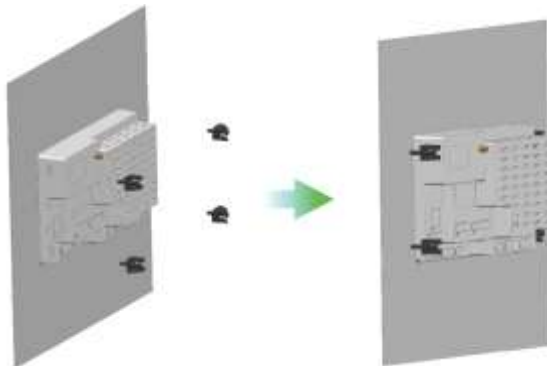

# Installation – Electrical



**WARNING!** Incorrect wiring can damage the sensor or cause it to work incorrectly.

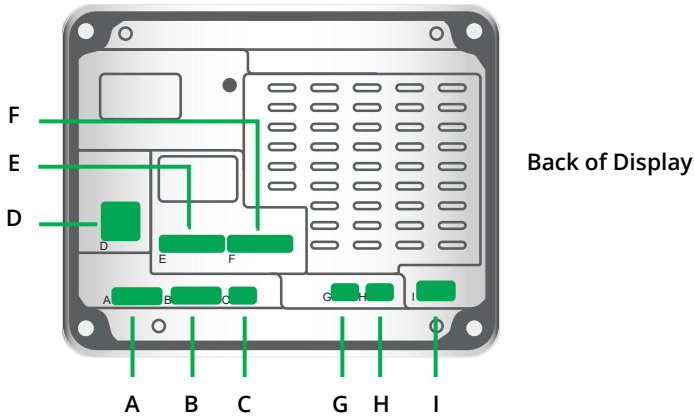

- A & B** RS485 Input
- C** RS485 Output
- D** Ethernet Input / Output
- E & F** Analog Input
- G & H** Relay output
- I** Power Input

Wall Mount or  
Din Rail Mount

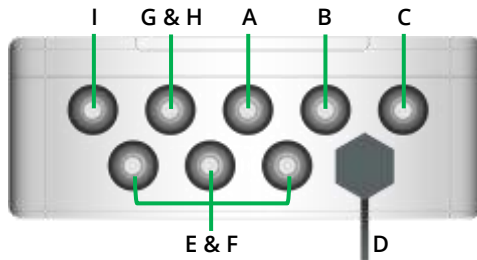

## Wiring

	Pin 1	Pin 2	Pin 3	Pin 4	Pin 5	Pin 6	Pin 7	Pin 8
<b>Connections A &amp; B: RS485 Input</b>								
Con. A	NC	VO-	VO+	RS485 A+	RS485 B-	RS485 Ground		
Con. B	NC	VO-	VO+	RS485 A+	RS485 B-	RS485 Ground		
<b>Connection C: RS485 Output</b>								
Con. C	RS485 A+	RS485 B-	RS485 Ground					
<b>Connection D: Ethernet Input / Output</b>								
Con. D	Ethernet Port (1G Ethernet Interface)							
<b>Connections E &amp; F: Analogue Input</b>								
Con. E	VO+	VO-	VI_D-	VI_D+	VO+	VO-	VI_C-	VI_C+
Con. F	VO+	VO-	VI_B-	VI_B+	VO+	VO-	VI_A-	VI_A+
<b>Connections G &amp; H: Relay Output</b>								
Con. G	NO	COM	NC					
Con. H	NO	COM	NC					
<b>Connection I: Power Input</b>								
Con. I	L V+	N V-	Ground					

For wall mount and din rail installations, to access the back of the display:

(1) Remove the wall mounting bracket

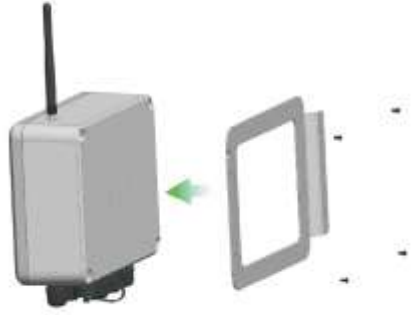

(2) Unscrew the back cover



(3) Separate the HMI from the back cover



# Configuration



# Display Overview

## Values Screen

### Data Logging

Blinking red dot indicates data logging is in progress

### Drop Down Menus

Use the drop-down menus to select the Measurement Site and / or Measurement Points

### Screenshot

**View more data**  
Swipe Up or Down on a card to see more data for that card

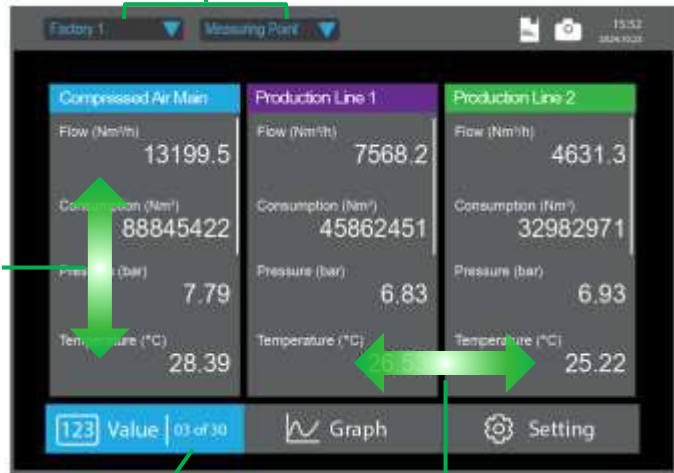

**Cards**  
Number of Cards available (eg sensors, measurement points)

**View other Cards**  
Swipe Left or Right to view other sensors / Measurements

# Graph Screen

**Dropdown**  
Use the drop-down menu to select the data you to view

**X-Axis Time Scale**  
Change the timescale on the X-Axis from 5 min to 8 hours

**Reset data**

**Short Press**  
Turn graph on or off

**Long Press**  
Configure graph

**Move Graph**  
Use two fingers to move the graph around or to

**Sliding bar**  
Slide the bar to change the time period shown in the graph

Parameter	Value
Dew Point	10 °Cd
Rel. Humidity	35.4%RH
Abs. Humidity	8881.6 mg/m3
Moisture	1754.2 ppmv
Pressure	0.6 MPa

## Settings Screen

There are two levels of access to the Settings screen:

- **General Users:**
  - View / update Modbus (Fieldbus) settings
  - Start / stop data logging
  - Download data and screenshots
  - Change general system settings such as language and screen brightness
- **Admin User:**
  - Do everything the General User can do, plus:
  - Add, edit, delete sensors (devices)
  - Add, edit, delete locations and measure points
  - Add, edit, delete Alarms
  - Change the Admin password

### Default settings Screen

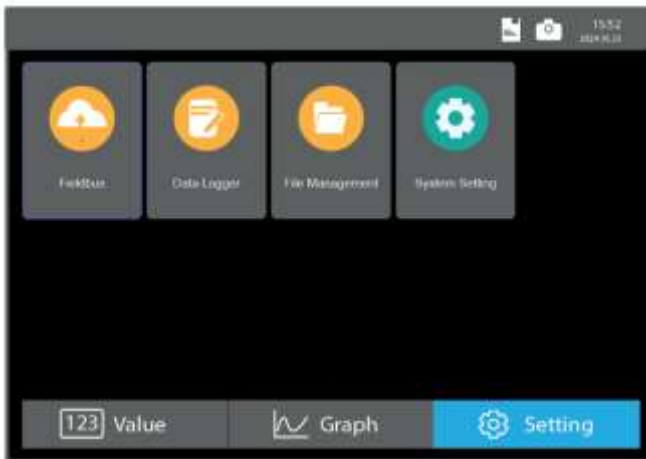



## Admin settings Screen – Password Protected



# Configure Sensors

## To add devices:

- Go to **Settings > System Setting > User Management**
- Enter the password: **160929**
- Click **OK**, then click **OK** again
- Go to **Device Connection**
- Click on the orange hand icon  in the top right corner
- Select which type of device you want to add:

Option	Use
<b>Our brand devices</b>	Automatically search for, and add, CAA Sensor's dew point sensors and flow meters only
<b>Third-party devices</b>	Manually add Modbus devices <b>Note:</b> click the add button  to add more registers (channels / measurements)
<b>Analog devices</b>	Manually add Analogue devices, ie: 0-20mA, 4-20mA, 0-1V or 0-10V signals
<b>Virtual devices</b>	Create calculated channels, eg: Total Power = power from meter 1 + power from meter 2
<b>Wi-Sun devices</b>	Not in use

- Fill out the form
- Press the back arrow (top left of screen) to save changes

## To edit or delete devices:

- Go to **Settings > System Setting > User Management**
- Enter the password: **160929**
- Click **OK**, then click **OK** again
- Go to **Device Connection**
- Click on the blue pencil icon to edit a device's details
- Click on the gray trash can to delete a device.

# Device Connection Screen

**Back Arrow**  
Save Changes  
Go back one menu

**Clear All**  
Delete all devices

**Add Device**

Device description	Device type	Serial No.	Port	Address	Operation
Dew Point	ANALOG Device	—	—	300	
Factory Flow	Third Party Dev...	15678249834	A	1	
Gas Temp	ACS	0	A	2	
Total Power	VIRTUAL Device	—	—	400	

**View more Devices**  
Swipe Up or Down to see more devices

**Edit Device**  
Edit device details

**Delete Device**

 **Note:** The green search button will search for a CAA Sensors' dew point sensor or flow meter and automatically populate the device data. It does **not** work with other devices.

## Virtual Devices

Virtual devices are devices (data / measurement points) that are calculated from measured data.

You can use basic calculations (add, subtract, multiple and divide) to create virtual devices.

Example: You want to measure Total Power from 3 power meters.

- The measured data is power from each of the 3 power meters (ie: power from meter 1, power from meter 2 and power from meter 3)
- The virtual device is 'Total Power' as this is calculated from the measured data above.
- Total Power (virtual device) = power 1 + power 2 + power 3

## How to add a Virtual Device

### Preset Formulas

For Preset formulas, the right side of the screen displays required parameters.

- Click the Add Parameter button to enter the parameter configuration interface.
- Select the channels that need to be involved in the calculation by checking the checkboxes in front of the channels.
- Click the back arrow in the upper left corner of the screen to save the formula and return to the previous screen.

### Custom Formulas

Use the text box and a channel list on the right side of the interface to create a custom formula.

- Click the text box to bring up the calculator.
- Select a channel from the list to insert its index into the textbox.
- Use the calculator in conjunction with the textbox to create a customised formula.
- Click the back arrow in the upper left corner of the screen to save the formula and return to the previous screen.

### Errors

If there is an error in the formula, the text in the textbox will turn red. It will revert to white once the formula is corrected.

### Edit or Delete a Virtual Device

On the Device Connection screen:

- Click the blue pencil icon  to edit the virtual device
- Click on gray trash can  to delete the virtual device

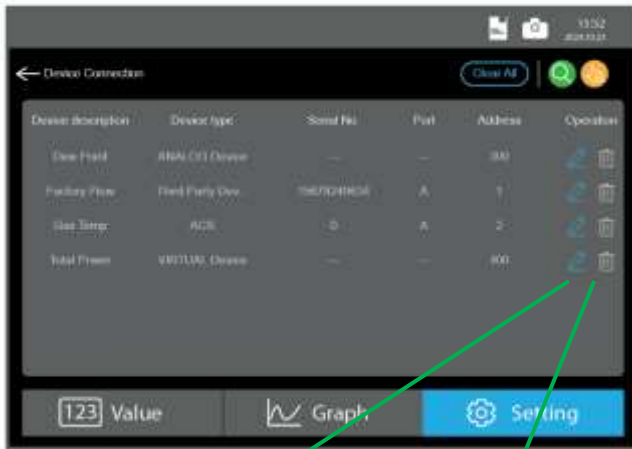

Edit Virtual Device



Delete Virtual Device

# Configure Layout

After you have added devices, you can add Locations and Measure Points (ie data). This information will be displayed on the Value screen (see below) and the Graph screen

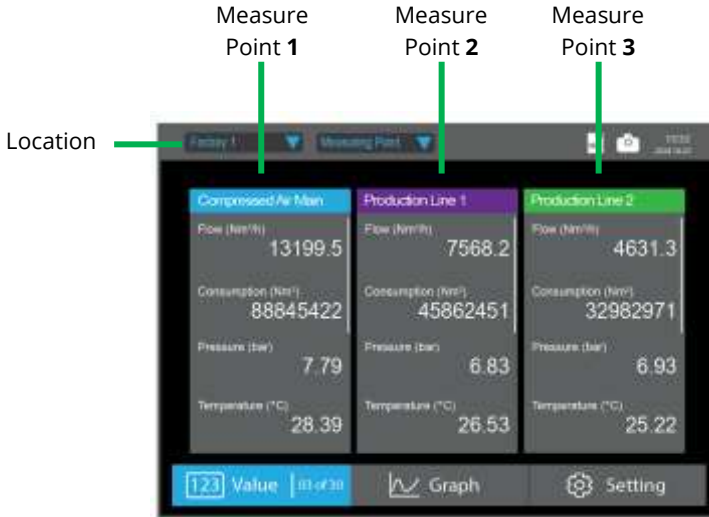

## Location

You must have at least one location. Location allows you to group relevant data

- Example: You might want to monitor how much electricity is being used by specific equipment. In this case the Location would be "Electricity", and the data (Measure Points) should be the equipment names
- Example: You might want to monitor the performance of two production lines. In this case, you would have two Locations – (i) Production Line 1 and (ii) Production Line 2
- Example: You might want to monitor which alarms have been triggered. In this case, your Location would be 'Alarms' and the Measure Points would be the various alarms

## Measurement Points

Measure Points are channels / data from each device that you want displayed for a specific location. Measure Points will be displayed on the Value Screen (see above). They can also be used to create graphs.

You can select data from different devices to be under one measure point.

- Example: Measure Point 1 could show (i) pressure dew point from the dew point sensor and (ii) ambient temperature from the temperature sensor

You can compare data from different areas

- Example: Measure Point 1 could show performance data from Compressor Room 1. Measurement Point 2 can show performance data from Compressor Room 3

### To configure the layout:

- Go to **Settings > System Setting > User Management**
- Enter the password: **160929**
- Click **OK**, then click **OK** again
- Go to **Layout Setting**

### Locations:

- Click on the pencil icon to edit the location's name
- Click on the trash can icon to delete the location
  - Deleting a location will delete all measurement points associated with that location
- Click on the + button to add another location

### Measure Points

- **Note:** Make sure the correct location is selected before you add Measurement Points. The selected location will be highlighted blue
- Click '**Configuration**' to select which devices and which channels you want shown on the main screen
  - Scroll through the list to find the device you want
  - Under 'Channels', click 'Expand'
  - Select the channel(s) you want to display

- Repeat these steps until you have selected all the channels you want displayed for that Measure Point.
- Click on the + button to add more Measurement Points
- Click on the pencil icon to edit the Measurement Points name
- Click on the trash can icon to delete the Measurement Points

**Save**

- Click the back arrow to save changes

## Layout Settings Screen

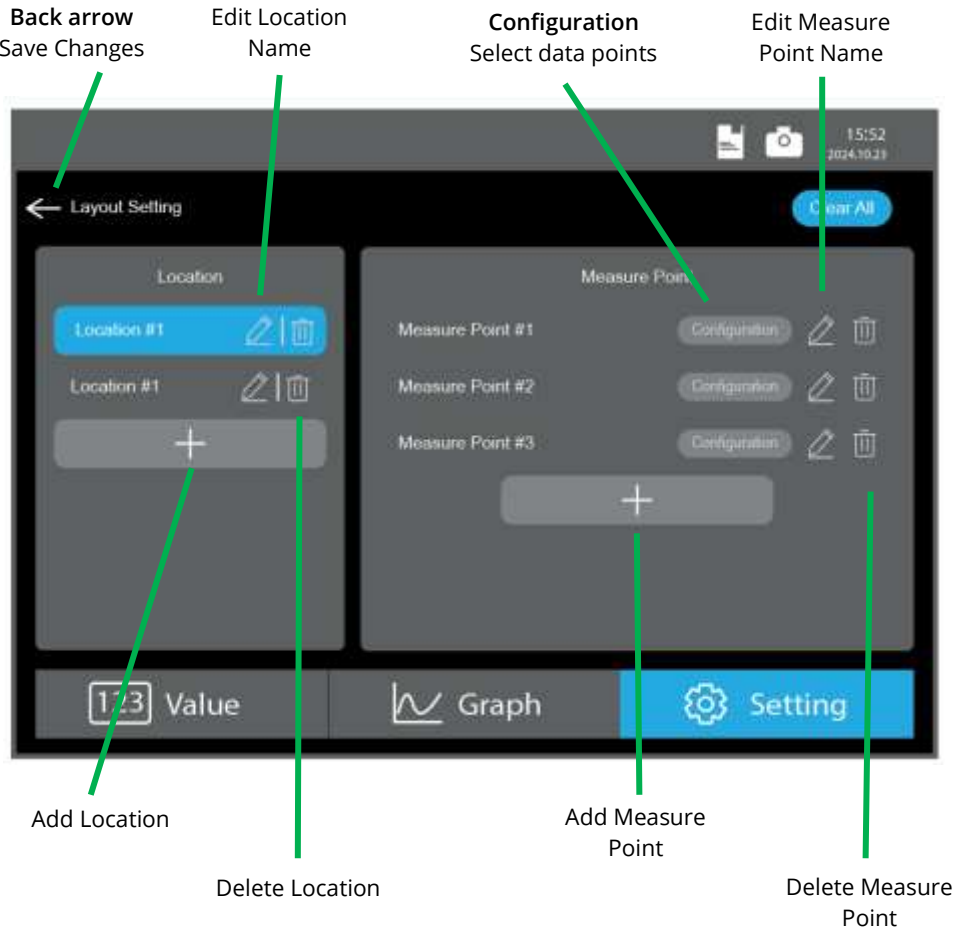

# Configure Alarms

You can set alarms for one or more channels. Two alarm relays are included with the HMI – Relay G and Relay H. These relays are rated to 24 VDC, 3A.

If an alarm is triggered, a flashing alarm icon will appear in the top right of the screen.

## To configure alarms:

- Go to **Settings > System Setting > User Management**
- Enter the password: **160929**
- Click **OK**, then click **OK** again
- Go to **Alarm Setting**

## Add new alarm

- Click the Add button  to add a new alarm
- Fill in the form and click OK
  - Location – Point – Channel = Select which channel you want to set an alarm for
  - **Threshold** = trigger point, ie the point at which you want the alarm to trigger
  - **Hysteresis** = specifies when the alarm will reset
    - Eg: if the threshold is 25, the Hysteresis is 3 and the Direction is 'Down', the alarm will reset when the reading reaches 28 (ie 25+3)
    - Eg: if the threshold is 25, the Hysteresis is 3 and the Direction is 'Up', the alarm will reset when the reading reaches 22 (ie 25-3)
  - **Direction**
    - If you want the alarm to trigger when the value goes **above** the threshold, choose '**Up**'
    - If you want the alarm to trigger when the value goes **below** the threshold, choose '**Down**'
  - **Relay** = select if you want to output the alarm to an external light / buzzer / screen. Choose Relay G or H. Alternatively, if you don't want to output the alarm, select 'None'

### To edit an alarm

- Click on the setting you want to edit
- Enter new setting

### Delete Alarm

- Click on the trash can next to the alarm

### Save

- Click the back arrow to save changes

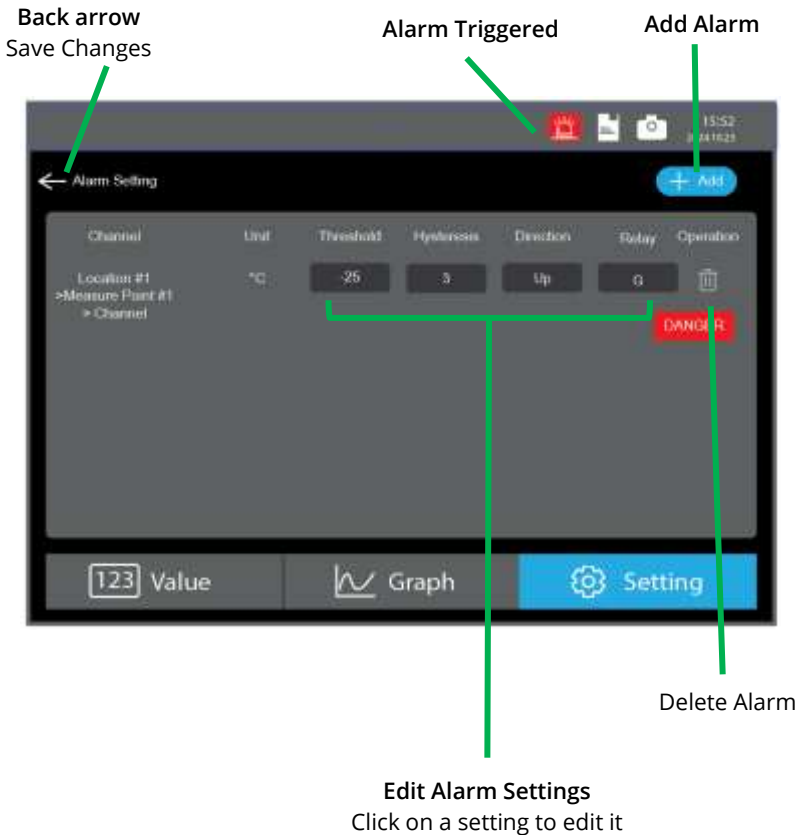

# Alarm Relay Output

The HMI has two relay outputs - G and H - with a specification of 230 VAC, 3A.

	Pin	Signal	Description
Connector G / H	1	NO	Normal Open i.e. being open when the power is off and alarm is not triggered; Being closed when alarm is triggered
	2	COM	Ground
	3	NC	Normal Closed i.e. being closed when the power is off and alarm is not triggered; Being open when alarm is triggered

## Normally Open or Normally Closed?

If you need to **turn on a device** (such as a sound and light alarm) when the alarm condition is met (measurement value exceeds the threshold), connect the device to Pin 1 (NO).

If you need to **turn off a device** (e.g. a compressor) when the alarm condition is met, connect the device to Pin 3 (NC).

## Relay Diagram

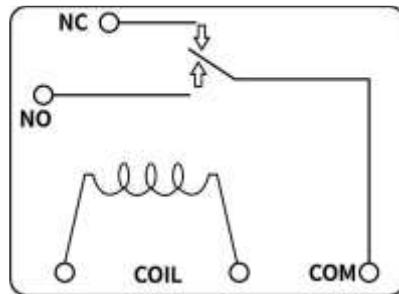

# Settings

There are two Setting screens – (i) Default view which is assessable to all users and (ii) an Admin view which is password protected. Refer to ‘Settings’ section for details on each setting.

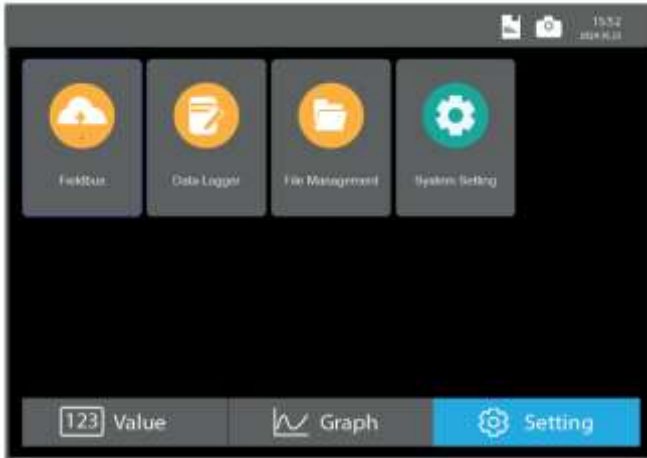

To access the Admin Settings screen, go to:  
 Settings > System Setting > User Management  
 enter the password: 160929

Setting Menu		User Access
<b>Fieldbus</b>		
Modbus RTU	View / edit Modbus RS485 settings	Everyone

**Default Settings:**

Setting Menu	User Access
--------------	-------------

- Address: 1
- Baud Rate: 9600
- Data Length: 8
- Parity bit: None
- Stop bit: 1
- Response Timeout: 1 second
- Response delay: 0ms
- Frame interval (char): 1
- Frame interval (us): 100

Modbus TCP	View / edit Modbus TCP (ethernet) settings	Everyone
------------	--	----------

**Default Settings:**

- Automatically obtain an IP address (DHCP)

Protocol	View / download the Modbus Register Address table.	Everyone
----------	--	----------

<b>Data Logger</b>
--------------------

Data Logger	<ul style="list-style-type: none"> <li>• Configure the data logger</li> <li>• Start / Stop logging</li> </ul>	Everyone
-------------	---	----------

**Note:** When the HMI is logging data, a data logging icon will appear in the status bar. When the HMI stops logging data, the data logging icon will disappear

<b>File Management</b>
------------------------

Record Files	View, export or delete recorded data	Everyone
--------------	--------------------------------------	----------

Screenshots	View, export or delete screenshots	Everyone
-------------	------------------------------------	----------

<b>System Setting</b>
-----------------------



Language	Select your language	Everyone
----------	----------------------	----------

Screen Setting	<ul style="list-style-type: none"> <li>• Adjust screen brightness</li> <li>• Set the 'off screen' time duration.                             <ul style="list-style-type: none"> <li>○ The screen goes dark after this time.</li> <li>○ Touch the screen to wake it up / brighten the screen</li> </ul> </li> </ul>	Everyone
----------------	--	----------

Date & Time	Adjust the system current date and time.	Everyone
-------------	--	----------

Setting Menu		User Access
System Upgrade	Update the HMI firmware  To update the firmware: <ul style="list-style-type: none"> <li>• Insert a USB with the new firmware</li> <li>• Follow the prompts</li> </ul>	Everyone
Configuration Backup	Import or export configuration files	Everyone
System Restart	Restart the system	Everyone
User Management	Access advanced features	Admins
System Information	<ul style="list-style-type: none"> <li>• View the hardware and software information</li> <li>• View the IP address used by the HMI</li> <li>• View the CPU temperature</li> <li>• View Memory information</li> <li>• View the number of times the HMI has been restarted</li> <li>• View the maximum number of sensors the HMI can support</li> </ul>	Everyone

**Device Connection** (Note: password protected) (Default Password: 160929)

	<ul style="list-style-type: none"> <li>• Search for a CAA Sensors' dew point sensor or flow meter</li> <li>• The search feature will automatically populate the sensor information</li> </ul>	Admins
	<ul style="list-style-type: none"> <li>• Add a Modbus device</li> <li>• Add an Analogue device</li> <li>• Create a virtual channel (ie a calculated channel)</li> <li>• Note: "Wi-Sun devices" is not used</li> <li>• Note: "Our Brand devices" will find CAA Sensors' dew point sensors and flow meters only</li> </ul>	Admins

**Device Layout** (Note: password protected) (Default Password: 160929)

Location	<ul style="list-style-type: none"> <li>• Create, edit, rename, delete a location eg: Compressor Room, Production Line 1, etc</li> <li>• Devices can be grouped under specific locations</li> </ul>	Admins
----------	--	--------

Setting Menu		User Access
Measurement Point	<ul style="list-style-type: none"> <li>Select which measurements you want displayed for that Location</li> <li>One or more measurement points can be saved under multiple locations</li> <li>Create, edit, rename, delete a measurement points</li> </ul>	Admins
<b>Sensor Setting</b> (Note: password protected) (Default Password: 160929)		
-	<ul style="list-style-type: none"> <li>Not used</li> </ul>	Admins
<b>Alarm Setting</b> (Note: password protected) (Default Password: 160929)		
-	<ul style="list-style-type: none"> <li>Add, edit, delete alarms</li> <li>Multiple alarms can be created</li> </ul>	Admins

# Modbus Communication

The HMI acts as a slave device and uploads data to the master device (PLC, DCS, SCADA, etc.).

## Modbus RTU (RS485)

### Default Settings

The default Modbus RS485 settings are shown in the table below.

To view / edit the Modbus RS485 settings, go to: **Settings > Fieldbus > Modbus RTU**

Address	Baud Rate	Frame / Parity / Stop Bit	Response Time	Response Delay	Frame Spacing
1	9600	8 / N / 1	1 Sec	0 Milliseconds	7 Characters

### Register Definition

Logic channels, data and holding registers

- Read holding register data using MODBUS instruction 0x03.
- Write to a single holding register using MODBUS instruction 0x06,
- Write to multiple holding registers consecutively using instruction 0x10.
- Write to the coil register using instruction 0x05.

### Process Data Format

The HMI supports two data types: (i) IEEE 754 floating-point numbers and (ii) unsigned integers.

#### Float Format

Value (Decimal)	IEEE 754 float	Register N		Register N+1	
		High Byte	Low Byte	High Byte	Low Byte
123.4	0x42F6CCCD	0xCC	0xCD	0x42	0xF6

### Unsigned int format

Value (Decimal)	Unsigned int	Register N		Register N+1	
		High Byte	Low Byte	High Byte	Low Byte
123456789	0x075BCD15	0xCD	0x15	0x07	0x5B

### Byte Order

The data is in small byte order, with the least significant bit transmitted first, i.e: Little Endian Byte Swap.

- 32bit: CD AB
- 64 Bit: GH EF CD AB

## Modbus TPC Settings

The HMI supports Ethernet communication and can be configured with a static IP address or automatically obtain an IP address using the DHCP function.

To view / edit the Modbus TCP settings, go to: **Settings > Fieldbus > Modbus TCP**

### Default Settings

The factory setting is to automatically obtain an IP address (DHCP).

## Modbus Holding Registers: Process Data Address Table

The register address table for the HMI is not fixed. Different types of sensors require different register address tables.

To view the Holding Register information for each sensor go to: **Settings > Fieldbus > Protocol**

To download the Holding Register information, insert the USB drive and go to: **Settings > Fieldbus > Protocol**, then click **Export** to download the register address table to your USB.

# Trouble Shooting



# Warranty

CAA Sensors provides a 12-month warranty for all sensors. The warranty covers materials and workmanship under the stated operating conditions from the date of delivery. Please report any findings immediately and within the warranty time.

If faults occur during the warranty period CAA Sensors will repair or replace the defective unit, without charge for repair labour and material costs but there is a charge for other services such as labour to remove or reinstall the instrument, transport and packing. Warranty repairs do not extend the period of warranty.

The following damage is excluded from this warranty:

- Improper use and non-adherence to the user manual.
- Use of unsuitable accessories.
- External influences (e.g. damage caused by vibration, damage during transportation, excess heat or moisture).

The warranty is cancelled when one of the following situations occurs:

- The user opens the measurement instrument

without a direct request written in this manual.

- Repairs or modifications are undertaken by third parties or unauthorised persons.
- The serial number has been changed, damaged or removed.

Other claims, especially damage occurring on the outside of the instrument (eg dents, marks), are not included unless responsibility is legally binding.

# Calibration

The sensor is calibrated before delivery. The calibration date is printed on the certificate which is shipped with the sensor.

Sensors require calibration to remain accurate. The frequency of calibration depends greatly on the level of contamination within your system.

We recommend you calibrate the sensor every 2 years (provided the sensor is not exposed to contaminants or relative humidity above 85%). Calibration is excluded from the product warranty. For more information, contact CAA Sensors:

- Phone: +61 494095632
- What'sApp: +61 494095632
- E-mail: [sales@caasensors.com](mailto:sales@caasensors.com)

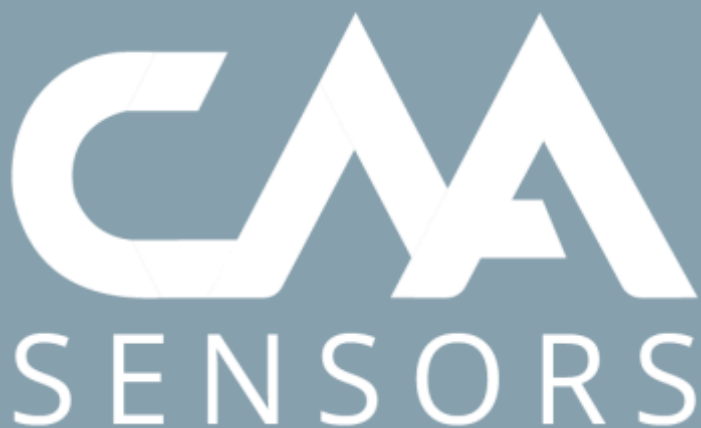

CAA Sensors Pty Ltd

Address: 2/7 Narabang Way, Belrose NSW 2085, Australia

E-mail: [sales@caasensors.com](mailto:sales@caasensors.com)

Website: [www.caasensors.com](http://www.caasensors.com)